

alu-rEX

# PRODUCT GUIDE



TRUST YOUR GUTTERS



When Guy and Stéphane Brochu founded Alu-Rex in 2001, it was because they believed there was a smarter, more reliable way to protect homes from the elements. But just as importantly, they believed there was a better way to build a business — through innovation, trust, and genuine care for their customers and partners.

From a small family venture in Quebec to a North American leader, Alu-Rex has grown by constantly challenging conventions, pushing technology forward, and raising the bar for performance and durability.

More than 25 years later, our products, people, and purpose continue to evolve — but our commitment to doing things right remains unchanged.

At Alu-Rex, innovation is what we build.

**TRUST IS WHAT WE STAND ON.**



# TRUST YOUR GUTTERS

**TRUST YOUR GUTTERS** is more than a slogan, it's a promise. A promise that every product, every partner, and every installer carries the same commitment to excellence in building strong, lasting gutter systems, relationships, and trust.



# TOP 5 REASONS TO CHOOSE ALU-REX



## SAVING INSTALLATION TIME

Cut labor costs and install more jobs everyday.



## EASILY SELLS ON EVERY JOB

Half of your clients need a leaf guard, but 100% need the strongest hanger on the market.



## COMPETITIVE PRICING + CUTTING-EDGE TECHNOLOGY

Our range of products allows you to implement a good, better, best strategy.



## LIFETIME WARRANTY

The only gutter hanger offering a lifetime sturdiness warranty for your clients!



## HOMEOWNER BENEFITS

The best quality-to-price ratio in the industry. A 2-in-1 product for homeowners: Double Pro<sup>®</sup> & Hover Pro<sup>™</sup>.

# ALU-REX'S INNOVATIONS

“ At Alu-Rex, we are very proud of every patent we have developed, but there are two patents that really set Alu-Rex apart: the continuous hanger™ revolutionized the way we install gutters and the dual-layer revolutionized the way we protect gutters.

Tommy Brochu,  
VP of Business Development ”

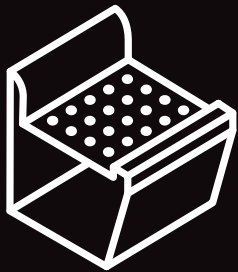

**UNMATCHED  
DURABILITY OF THE  
CONTINUOUS HANGER™**

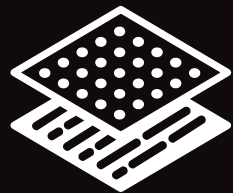

**TWO LAYERS  
OF PERFORATED  
ALUMINUM**

“ Alu-Rex is born from innovation. It's more than a core value — it's in our DNA.

Kevin Brochu,  
VP of Operations ”



**CONTINUOUS HANGER™**

# FASTENING SYSTEMS OVER THE YEARS



**1980**

**SPIKES AND FERRULES**

**1990**  
**SPACED BRACKETS**

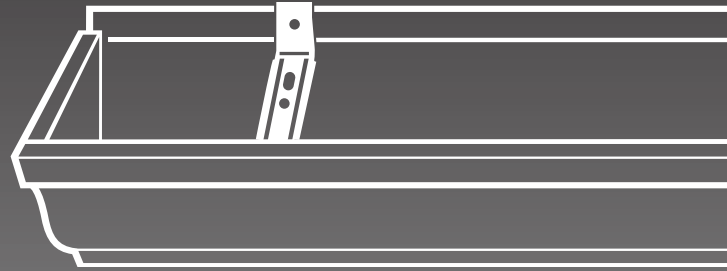

**TODAY**  
**CONTINUOUS HANGERS™**

The continuous hanger™ is the only fastening system that ensures gutters remain strong and rigid along their entire length. It eliminates the weaknesses that other systems generate between nails and spaced hangers.

# CONTINUOUS HANGERS™: EXPLAINED

Rain gutters are commonly installed using spaced hangers, creating weak points along the gutter between each bracket.

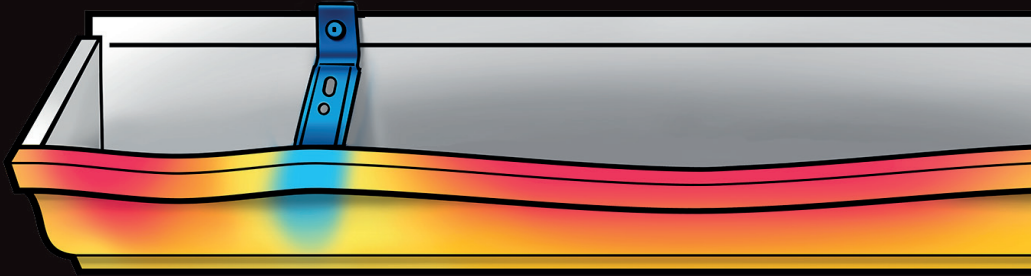

To avoid weak spots, hundreds of hangers would need to be added, which is not a very efficient practice.

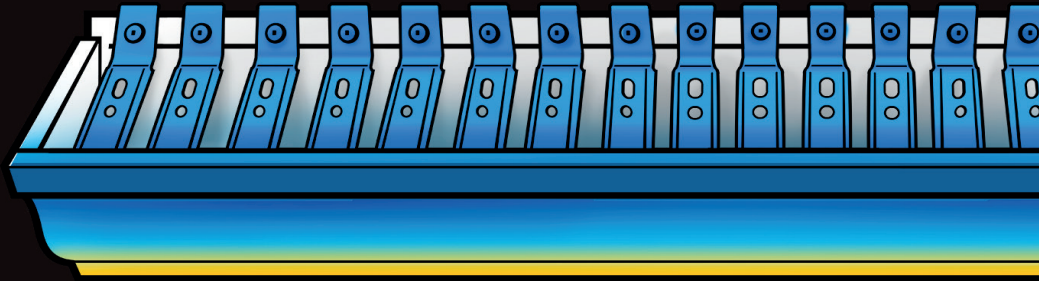

With a **continuous hanger™**, the rain gutters are reinforced along their entire length.

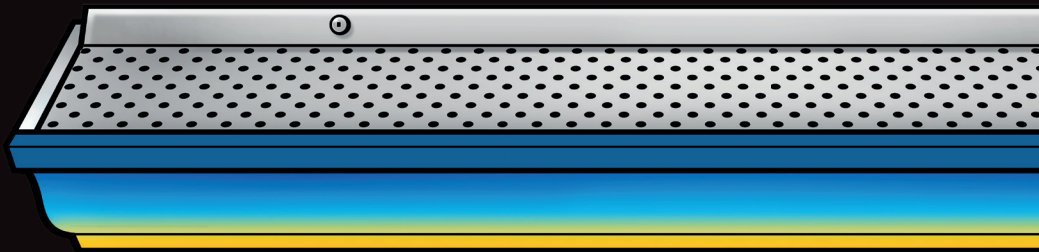

# LEVEL UP YOUR INSTALLATIONS

Your work deserves products that match your expertise. Don't stay stuck in single-layer solutions when the next generation is already here.

## DELIVER BETTER PERFORMANCE. EARN BIGGER REWARDS.

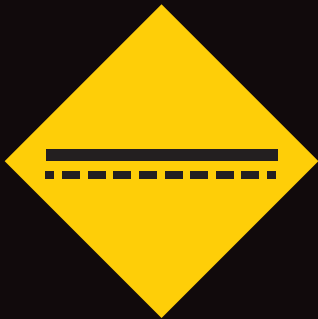

### DUAL-ACTION PROTECTION

Eclipse™ offset perforations + Vortex™ suction = superior clog-free reliability.



### PEACE OF MIND FOR HOMEOWNERS

Maximum drainage and debris protection, backed by innovation unmatched in the industry.



### ELITE RECOGNITION

Every dual-layer install means **double the Pro Hub** points for Elite installers — more marketing, faster.

**SWITCH TO DUAL-LAYER.  
EARN MORE.  
DELIVER MORE.**

double  pro<sup>®</sup>    hover.<sup>™</sup>  
pro    gutter  clean<sup>®</sup>  
pro



Explore  
Dual-Layer  
Products



**INNOVATION YOU CAN TRUST.  
REWARDS YOU CAN EARN.**

CONTINUOUS HANGER™

# COMPARISON OF GUTTER SYSTEMS



Sturdiness



Drainage

Spaced Brackets

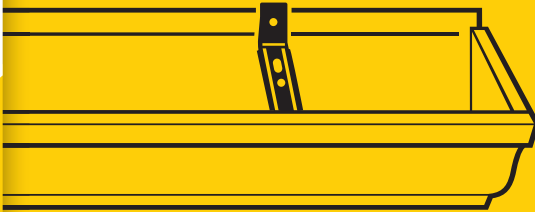

Weak points generated between nails and hangers

Reduced drainage capacity due to obstruction risk

DUAL-LAYER

t rex®  
Continuous Hanger™

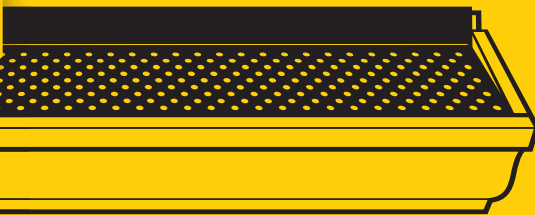

Support of 250 lb (113 kg) per linear foot

Drainage capacity of 29.7 in (754 mm) per hour per linear foot

**hover:**  
Additional reinforcement for gutters of 30 feet or more

Drainage capacity of 29.7 in (754 mm) per hour per linear foot

**hover.**  
Floating Continuous Hanger™

Support of 425 lb (193 kg) per linear foot

Drainage capacity of 40.6 in (1031 mm) per hour per linear foot

double pro®  
Continuous Hanger™  
with Built-In Gutter Guard

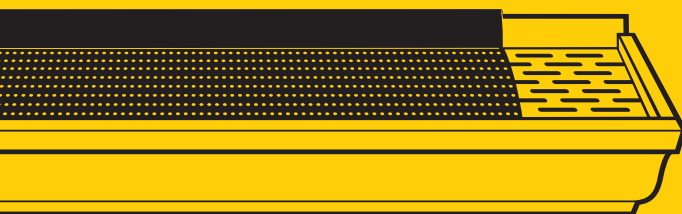

**hover.pro**  
Additional reinforcement for gutters of 30 feet or more

Drainage capacity of 40.6 in (1031 mm) per hour per linear foot

**hover.pro**  
Floating Continuous Hanger™  
with Built-In Gutter Guard



**Clog-Free Protection**





















**Sturdiness Warranty**



**Clog-Free Warranty**



**Thermal Protection Level**

<p>No protection</p> 	<p>No warranty</p> 	<p>No warranty (Maintenance required 4 to 5 times per year)</p> 	<p>Low</p> 
<p>Prevention of large debris from entering gutters</p> 	<p>Lifetime sturdiness warranty</p> 	<p>25-year prorated clog-free warranty (Maintenance required once per year)</p> 	<p>Good</p> 
<p>Prevention of large debris from entering gutters</p> 	<p>Lifetime sturdiness warranty</p> 	<p>25-year prorated clog-free warranty (Maintenance required once per year)</p> 	<p>Excellent</p> 
<p>Prevention of leaves and fine debris, including pine needles, from entering gutters</p> 	<p>Lifetime sturdiness warranty</p> 	<p>Lifetime clog-free warranty even in coniferous areas (Maintenance only if needed)</p> 	<p>Good</p> 
<p>Prevention of leaves and fine debris, including pine needles, from entering gutters</p> 	<p>Lifetime sturdiness warranty</p> 	<p>Lifetime clog-free warranty even in coniferous areas (Maintenance only if needed)</p> 	<p>Excellent</p> 

# THE ALU-REX PRODUCT HANGERS AT A GLANCE

## Complete installation and protection solutions for new gutters

**Double Pro®** is a patented dual-action gutter protection system. This continuous hanger™ with built-in guard is designed to stand up to the worst weather conditions in North America and keep your gutters free of debris and ice year after year.

**Hover Pro™** is the improved continuous fastening system with built-in guard that allows gutters to be suspended instead of screwing through them using the patented Floating™ technology. It is compatible with hemmed-back gutters.



Prevents buildup in

# HIGH

debris areas



Supports up to

# 425<sub>lb</sub>

per linear foot



Drains up to

# 40"

of water per hour



Passed

# ASTM

E2768 & E84-19B

## Installation solutions for new gutters

**T-Rex®** is a continuous fastening system for gutters. It mounts rain gutters solidly on houses, making them much sturdier and longer-lasting than those mounted with spikes and hangers spaced at intervals.

**Hover™** is the improved continuous fastening system that allows gutters to be suspended instead of screwing through them using the patented Floating™ technology. It is compatible with hemmed-back gutters.



Prevents buildup in

**LOW**

debris areas



Supports up to

**250** lb

per linear foot



Drains up to

**30"**

of water per hour



Passed

**ASTM**

E2768 & E84-19B

HANGER SYSTEM

double  pro<sup>®</sup>

# CONTINUOUS HANGER™ WITH BUILT-IN GUTTER GUARD



GUTTER GUARD



## vortex™ TECHNOLOGY

With the Vortex™ technology, the suction created by the two membranes makes it possible to drain three times more water than recorded in the heaviest storms.



## roll@back™ TECHNOLOGY

The Roll-Back™ technology sends excess rainwater back into the gutter for truly high-volume drainage capabilities of 40.6" of water per hour.

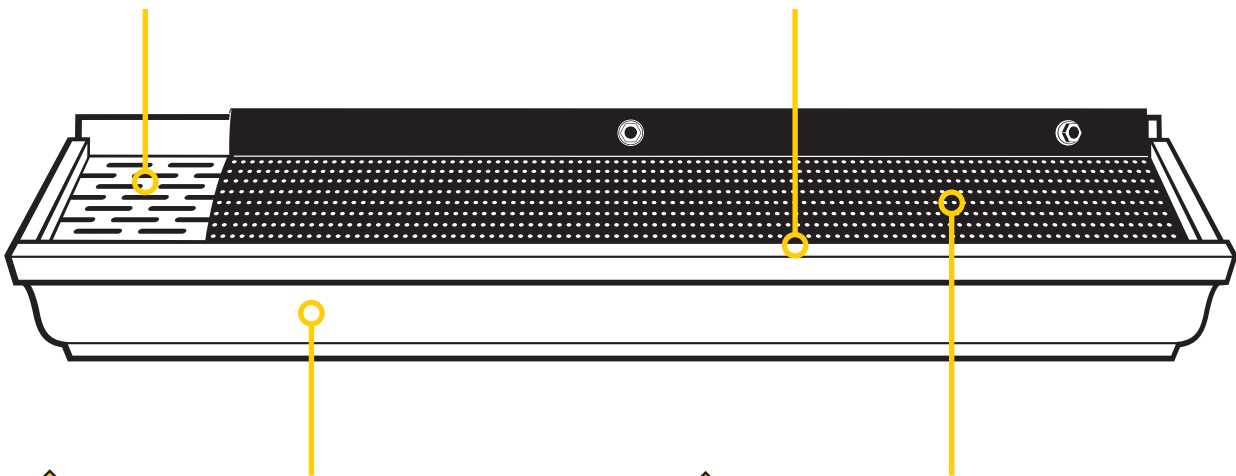

## Unparalleled Strength

The Double Pro® Continuous Hanger™ reinforces the rain gutter from end to end, ensuring uniform support along its entire length without any weak points. With the capacity to withstand up to 425 lb (193 kg) per linear foot, it guarantees unmatched durability.



## eclipse™ TECHNOLOGY

The offset holes of the Eclipse™ technology make it the perfect filter, allowing water to drain freely while blocking pine needles and leaves without ever getting clogged.



## WATCH THE QUICK STEPS OF AN INSTALLATION

See how it saves time, cuts costs, and lets you sell more jobs.



WATCH PRODUCT VIDEO

# TO ORDER



## D-11500 CARBON BLACK

**PRODUCT**  
 Aluminum  
 Carbon Black and clear backer  
 200 screws included  
 12 end trims included  
 Length: 7.5'  
 Top layer thickness: 0.017"  
 Bottom layer thickness: 0.014"

**PACKAGING**  
 24 pcs per ctn  
 180' per ctn  
 Ctn: 90" x 11" x 5" 47 lb  
 24 ctns per skid (4,320')  
 Skid: 92" x 45" 1,200 lb

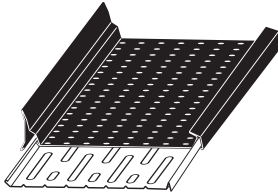

## D-11600 CARBON BLACK

**PRODUCT**  
 Aluminum  
 Carbon Black and clear backer  
 200 screws included  
 12 end trims included  
 Length: 7.5'  
 Top layer thickness: 0.017"  
 Bottom layer thickness: 0.014"

**PACKAGING**  
 24 pcs per ctn  
 180' per ctn  
 Ctn: 90" x 14" x 5" 56 lb  
 24 ctns per skid (4,320')  
 Skid: 92" x 45" 1,344 lb

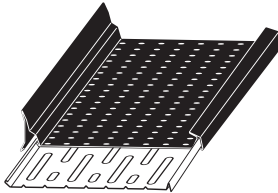

# ACCESSORIES

## END TRIMS

- > Aluminum + Flex-Seal™
- > Carbon Black
- > 12 trims per bag
- TR-500 (5")
- TR-600 (6")

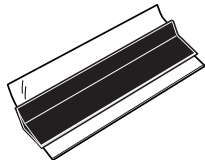

## SCREWS

- > Black head hex ¼"
- > Neoprene washer
- > Dacrotized steel
- > Bag of 100 screws # 10 1-½ screw
- SCREW1011/2BK (BLACK)



## CUT-FREE UNIVERSAL CORNERS

- > Aluminum
- > Carbon Black
- > Top layer thickness: 0.017"
- > Bottom layer thickness: 0.014"
- > 10 corners
- UCF-11500 (5")
- UCF-11600 (6")

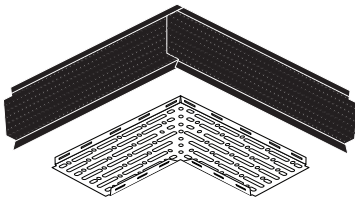

## UNIVERSAL ACCESSORY

- > Aluminum
- > Carbon Black
- > Top layer thickness: 0.017"
- > Bottom layer thickness: 0.014"
- > 10 corners or 20 access panels
- UA-11500 (5")
- UA-11600 (6")

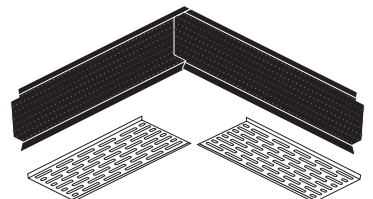



# CONTINUOUS HANGER™ FOR RAIN GUTTERS



## Sturdy Aluminum

Made from aluminum grade 3105 H24, with a sturdy 0.0175" thickness, our product guarantees remarkable strength. Count on its durability for top-notch performance in any setting.



## Self-Sealing Screws

The hanger is installed with black Dracotized self-sealing screws, steel-made #10 - 1½" (38 mm) in size, with ¼" (6.4 mm) hexagon heads and integrated rubber gaskets. It reinforces the gutter and reduces the risk of water seeping into the fascia. Screws are included with the product.

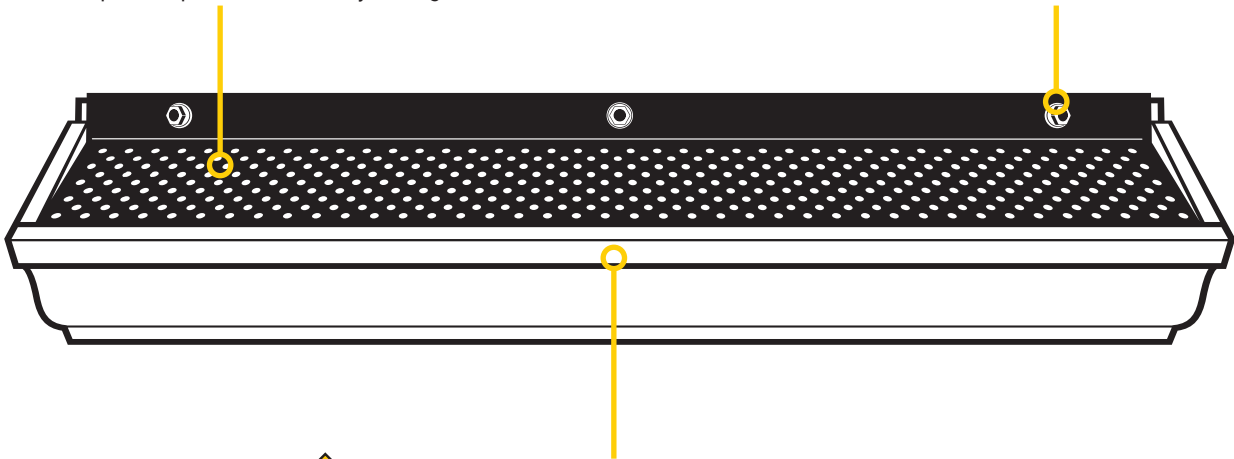

## Unparalleled Strength

With the T-Rex® Continuous Hanger™, your rain gutters are reinforced from end to end, ensuring uniform support across the entire length with no weak points. It can hold 250 lb (113 kg) per linear foot.

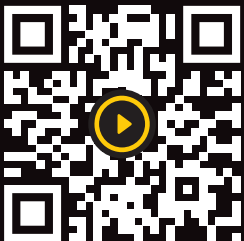

## WATCH THE QUICK STEPS OF AN INSTALLATION

See how it saves time,  
cuts costs, and lets  
you sell more jobs.



## WATCH PRODUCT VIDEO

# TO ORDER



## M-5200 B95 **CARBON BLACK**

**PRODUCT** Aluminum  
Carbon Black backer  
300 screws included  
Length: 7.5'  
Thickness: 0.017"

**PACKAGING** 48 pcs per ctn  
360' per ctn  
Ctn: 90" x 11" x 8" 56 lb  
20 ctns per skid (7,200')  
Skid: 92" x 45" 1,120 lb

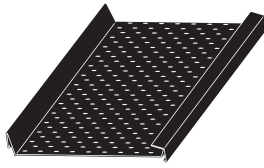

## M-5200 **MILL**

**PRODUCT** Aluminum  
Gold backer  
300 screws included  
Length: 7.5'  
Thickness: 0.017"

**PACKAGING** 48 pcs per ctn  
360' per ctn  
Ctn: 90" x 11" x 8" 56 lb  
20 ctns per skid (7,200')  
Skid: 92" x 45" 1,120 lb

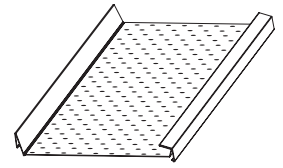

## M-6200 B95 **CARBON BLACK**

**PRODUCT** Aluminum  
Carbon Black backer  
300 screws included  
Length: 7.5'  
Thickness: 0.017"

**PACKAGING** 34 pcs per ctn  
255' per ctn  
Ctn: 90" x 13" x 6" 48 lb  
24 ctns per skid (6,120')  
Skid: 92" x 45" 1,152 lb

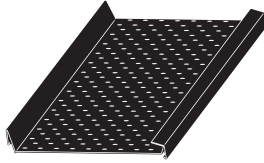

## M-6200 **MILL**

**PRODUCT** Aluminum  
Gold backer  
300 screws included  
Length: 7.5'  
Thickness: 0.017"

**PACKAGING** 34 pcs per ctn  
255' per ctn  
Ctn: 90" x 13" x 6" 48 lb  
24 ctns per skid (6,120')  
Skid: 92" x 45" 1,152 lb

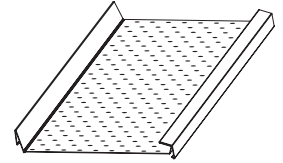

## M-7200 B95 **CARBON BLACK**

**PRODUCT** Aluminum  
Carbon Black backer  
200 screws included  
Length: 7.5'  
Thickness: 0.021"

**PACKAGING** 24 pcs per ctn  
180' per ctn  
Ctn: 90" x 13" x 8" 50 lb  
20 ctns per skid (3,600')  
Skid: 92" x 45" 1,000 lb

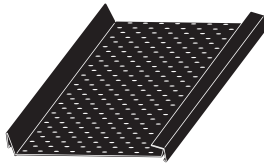

## M-7200 **MILL**

**PRODUCT** Aluminum  
Gold backer  
200 screws included  
Length: 7.5'  
Thickness: 0.021"

**PACKAGING** 24 pcs per ctn  
180' per ctn  
Ctn: 90" x 13" x 8" 50 lb  
20 ctns per skid (3,600')  
Skid: 92" x 45" 1,000 lb

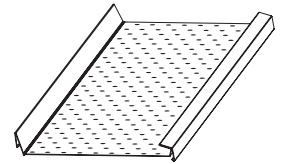

# ACCESSORIES

## OUTSIDE CORNERS

- > Aluminum
- > Carbon Black or Mill finish
- > Thickness: 0.017"
- > 20 pieces per ctn
- OC-5200D B95 (5" BLACK)
- OC-6200D B95 (6" BLACK)
- OC-7200D B95 (7" BLACK)
- OC-5200D (5" MILL)
- OC-6200D (6" MILL)
- OC-7200D (7" MILL)

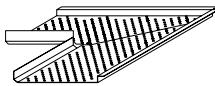

## ACCESS PANELS

- > Easy way to access the gutter
- > 20 pieces per ctn
- AP-5200 B95 (5" BLACK)
- AP-6200 B95 (6" BLACK)
- AP-5200 (5" MILL)
- AP-6200 (6" MILL)



## BITS

- > 6" long
- > Head hex 1/4"
- > Magnetic



## INSIDE CORNERS

- > Aluminum
- > Carbon Black or Mill finish
- > Thickness: 0.017"
- > 20 pieces per ctn
- > Includes 10 water diverters
- IC-5200D B95 (5" BLACK)
- IC-6200D B95 (6" BLACK)
- IC-7200D B95 (7" BLACK)
- IC-5200D (5" MILL)
- IC-6200D (6" MILL)
- IC-7200D (7" MILL)

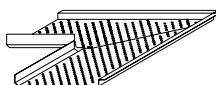

## SCREWS

- > Black or mill head hex 1/4"
- > Neoprene washer
- > Dacrotized steel
- > Bag of 100 screws
- # 10 1-1/2 screw
- SCREW1011/2BK (BLACK)
- SCREW1011/2 (MILL)



## WATER DIVERTERS

- > Included in inside corner boxes or 30 pieces per ctn
- > Thickness: 0.017"
- For M-5200 B95 (BLACK)
- For M-5200 (WHITE)

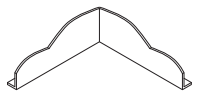

# hover.<sup>™</sup> pro

## Floating Continuous Hanger<sup>™</sup> with Built-In Gutter Guard



### Innovative Fastening System

Utilizing patented Floating<sup>™</sup> technology, gutters can be suspended from the building fascia without even puncturing them. As a result, they maintain their ability to change shape without expansion joint.



### eclipse<sup>™</sup> TECHNOLOGY

The offset holes of the Eclipse<sup>™</sup> technology make it the perfect filter, allowing water to drain freely while blocking pine needles and leaves without ever getting clogged.



### vortex<sup>™</sup> TECHNOLOGY

With the Vortex<sup>™</sup> technology, the suction created by the two membranes makes it possible to drain three times more water than recorded in the heaviest storms.



### Unparalleled Strength

The Hover Pro<sup>™</sup> Continuous Hanger<sup>™</sup> ensures uniform support from end to end. Its design avoids puncturing the gutters, preserving their condition, providing unparalleled strength and extended lifespan. It's the only gutter system you will ever need.



### Durability

Engineered for durability and resilience, the Hover Pro<sup>™</sup> stands strong against heavy weights and adverse weather. Its innovative Spring-Back<sup>™</sup> technology prevents gutter distortion, even under loads surpassing 425 lb per linear foot, by uniformly distributing pressure along its entire length.



INSTALLATION



→ Welcome beyond

# TO ORDER



## HP-11500 **CARBON BLACK**

**PRODUCT**  
 Aluminum  
 Carbon Black and clear backer  
 200 screws included  
 12 end trims included  
 Length: 7.5'  
 Top layer thickness: 0.017"  
 Bottom layer thickness: 0.014"

**PACKAGING**  
 24 pcs per ctn  
 180' per ctn  
 Ctn: 90" x 11" x 5" 47 lb  
 24 ctns per skid (4,320')  
 Skid: 92" x 45" 1,200 lb

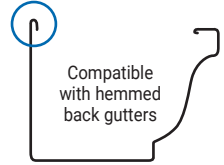
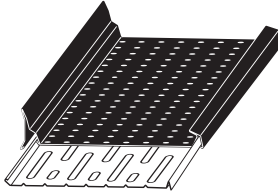

## HP-11600 **CARBON BLACK**

**PRODUCT**  
 Aluminum  
 Carbon Black and clear backer  
 200 screws included  
 12 end trims included  
 Length: 7.5'  
 Top layer thickness: 0.017"  
 Bottom layer thickness: 0.014"

**PACKAGING**  
 24 pcs per ctn  
 180' per ctn  
 Ctn: 90" x 14" x 5" 56 lb  
 21 ctns per skid (3,780')  
 Skid: 92" x 45" 1,229 lb

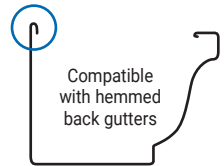
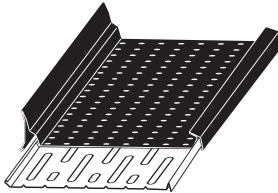

# ACCESSORIES

## END TRIMS

- > Aluminum + Flex-Seal™
- > Carbon Black
- > 12 trims per bag
- TR-500 (5")
- TR-600 (6")

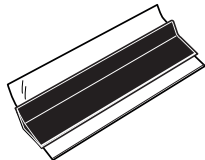

## SCREWS

- > Black head hex ¼"
- > Neoprene washer
- > Dacrotized steel
- > Bag of 100 screws # 10 1-½ screw
- SCREW1011/2BK (BLACK)



## CUT-FREE UNIVERSAL CORNERS

- > Aluminum
- > Carbon Black
- > Top layer thickness: 0.017"
- > Bottom layer thickness: 0.014"
- > 10 corners
- UCF-11500 (5")
- UCF-11600 (6")

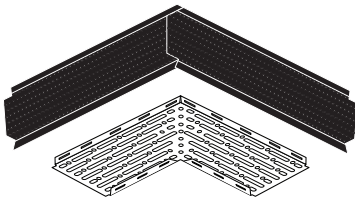

## UNIVERSAL ACCESSORY

- > Aluminum
- > Carbon Black
- > Top layer thickness: 0.017"
- > Bottom layer thickness: 0.014"
- > 10 corners or 20 access panels
- UA-11500 (5")
- UA-11600 (6")

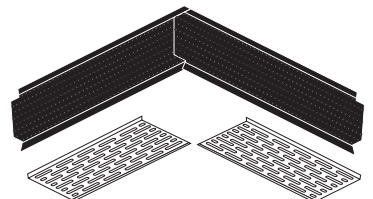

# hover.™ Floating Continuous Hanger™



## Durability

Engineered for durability and resilience the Hover™ stands strong against heavy weights and adverse weather. Its innovative Spring-Back™ technology prevents gutter distortion, even under loads surpassing 400 lb per linear foot, by uniformly distributing pressure along its entire length.



## Innovative Fastening System

Utilizing patented Floating™ technology, gutters can be suspended from the building fascia without even puncturing them. As a result, they maintain their ability to change shape without expansion joint.



## Unparalleled Strength

The Hover™ Continuous Hanger™ ensures uniform support from end to end. Its design avoids puncturing the gutters, preserving their condition, providing unparalleled strength and extended lifespan. It's the only gutter system you will ever need.



INSTALLATION



PRODUCT VIDEO



→ Welcome beyond

# TO ORDER



## H-5000 CARBON BLACK

- PRODUCT**
  - Aluminum
  - Carbon Black backer
  - 300 screws included
  - 12 end trims included
  - Length: 7.5'
  - Thickness: 0.017"
- PACKAGING**
  - 48 pcs per ctn
  - 360' per ctn
  - Ctn: 90" x 14" x 7" 56 lb
  - 18 ctns per skid (6,480')
  - Skid: 92" x 45" 1,282 lb

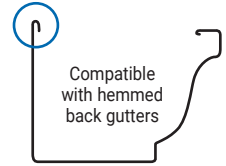
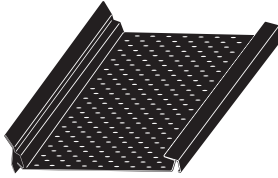

## H-6000 CARBON BLACK

- PRODUCT**
  - Aluminum
  - Carbon Black backer
  - 300 screws included
  - 12 end trims included
  - Length: 7.5'
  - Thickness: 0.017"
- PACKAGING**
  - 34 pcs per ctn
  - 255' per ctn
  - Ctn: 90" x 13" x 6" 54 lb
  - 21 ctns per skid (5,355')
  - Skid: 92" x 45" 1,246 lb

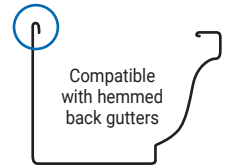
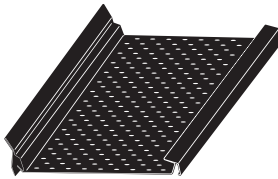

# ACCESSORIES

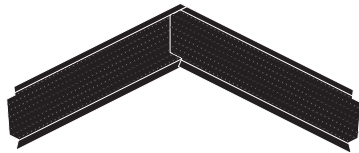

## UNIVERSAL CORNERS AND ACCESS PANELS (3 IN 1)

- > Aluminum
- > Carbon Black
- > Thickness: 0.017"
- > 15 corners or 30 panels per ctn
  - UA-5000 (5")
  - UA-6000 (6")

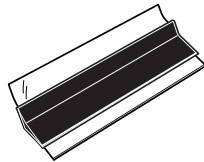

## END TRIMS

- > Aluminum + Flex-Seal™
- > Carbon Black
- > 12 trims per bag
  - TR-500 (5")
  - TR-600 (6")



## SCREWS

- > Black head hex ¼"
- > Neoprene washer
- > Dacrotized steel
- > Bag of 100 screws # 10 1-½ screw
- SCREW1011/2BK (BLACK)

# gutter clean<sup>®</sup> pro

## Retrofit Dual-Layer Microfiltration Gutter Protection

Born from decades of innovation and powered by patented technologies, Gutter Clean Pro<sup>®</sup> is the next generation of performance and reliability. It installs easily over existing gutters without replacement, effectively keeping out even fine debris like pine needles and preventing clogs.



### vortex<sup>™</sup> TECHNOLOGY

With the Vortex<sup>™</sup> technology, the suction created by the two membranes makes it possible to drain three times more water than recorded in the heaviest storms.



### eclipse<sup>™</sup> TECHNOLOGY

The offset holes of the Eclipse<sup>™</sup> technology make it the perfect filter, allowing water to drain freely while blocking pine needles and leaves without ever getting clogged.

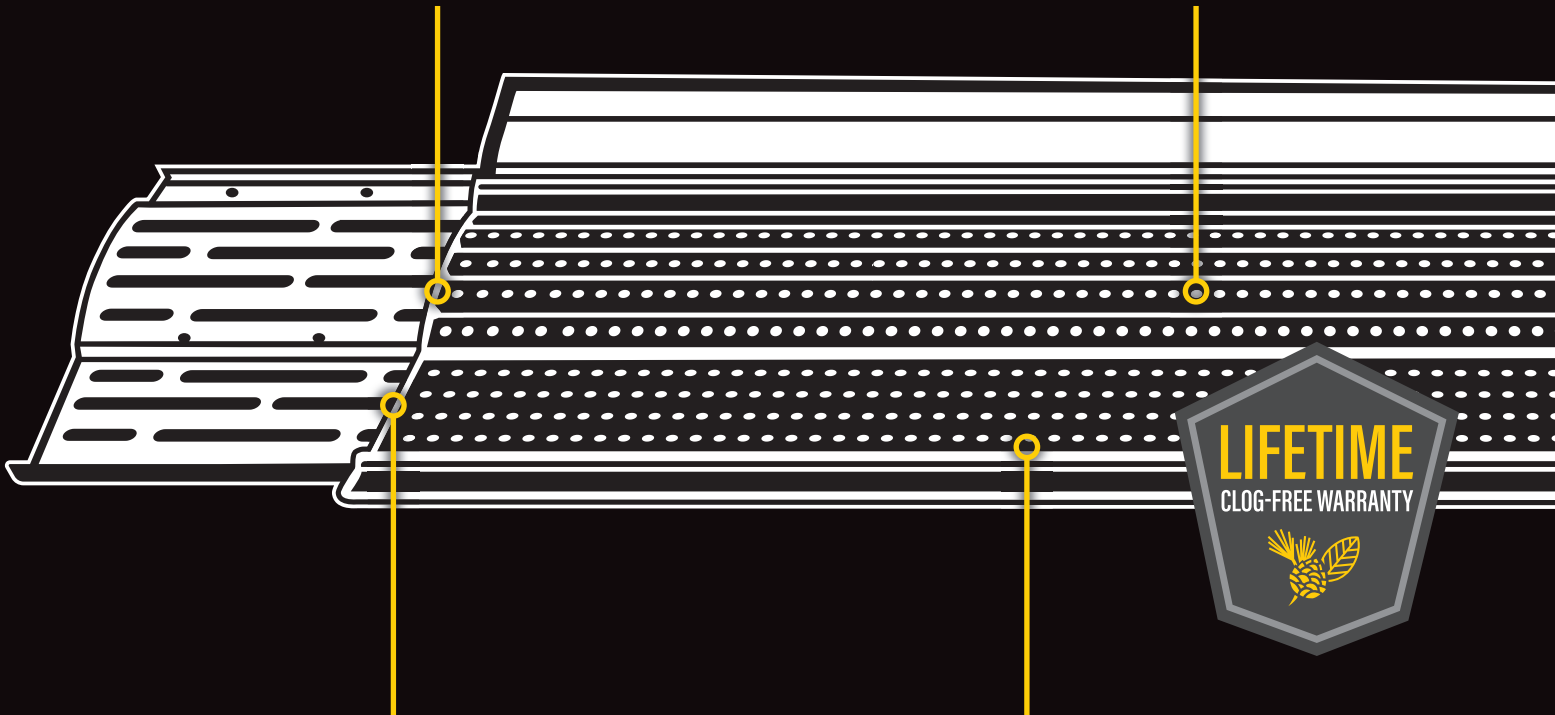

### Dual-Action Protection

A perfect combination of two perforated aluminum membranes: the lower layer with large oblong openings and the upper layer with precisely offset micro-perforations, forming an ideal filter.



### rollback<sup>+</sup> TECHNOLOGY

An enhanced U-shape created by the elevated front curve, redirects overflowing rainwater back into the gutter, even in extreme downpours. Built to handle high-volume drainage without spillover – tested and proven in real-world conditions.

# TO ORDER



## GCP-5300 CARBON BLACK

PRODUCT

Aluminum  
Carbon Black and clear backer  
1 bag of 12 vinyl trims  
for corner included  
Length: 7.5'  
Top layer thickness: 0.017"  
Bottom layer thickness: 0.014"

PACKAGING

24 pcs per ctn  
180' per ctn  
Ctn: 90" x 12" x 5" 44 lb  
24 ctns per skid (4,320')  
Skid: 92" x 45" 1,056 lb

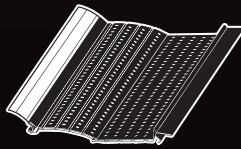

Fits all types of brackets



## GCP-6300 CARBON BLACK

PRODUCT

Aluminum  
Carbon Black and clear backer  
1 bag of 12 vinyl trims  
for corner included  
Length: 7.5'  
Top layer thickness: 0.017"  
Bottom layer thickness: 0.014"

PACKAGING

24 pcs per ctn  
180' per ctn  
Ctn: 90" x 14" x 5" 50 lb  
24 ctns per skid (4,320')  
Skid: 92" x 45" 1,200 lb

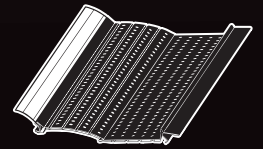

Fits all types of brackets



# ACCESSORIES

## CORNER TRIMS

- > Flexible vinyl strip
- > 12 trims per bag
- TRC-5300 (5")
- TRC-6300 (6")



Let It **Rain.** Let It **Fall.**  
We've Got You **Covered.**



# gutter clean<sup>SYSTEM</sup>

## RETROFIT RAIN GUTTER PROTECTION



The Gutter Clean System<sup>®</sup> is professionally installed over rain gutters without replacing them, keeping leaves and debris from getting into and clogging the gutters.



### flexi seal<sup>™</sup> TECHNOLOGY

Flex-Seal<sup>™</sup> technology is made of materials resistant to UV rays, mold and temperature variations ensuring, that the back of the gutter is watertight.

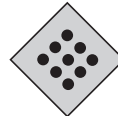

### alu-perf<sup>™</sup> TECHNOLOGY

Alu-Perf<sup>™</sup> technology's optimized perforations size create the perfect combination of maximum drainage and minimum debris. It drains 29.7" (754 mm) of water per hour.

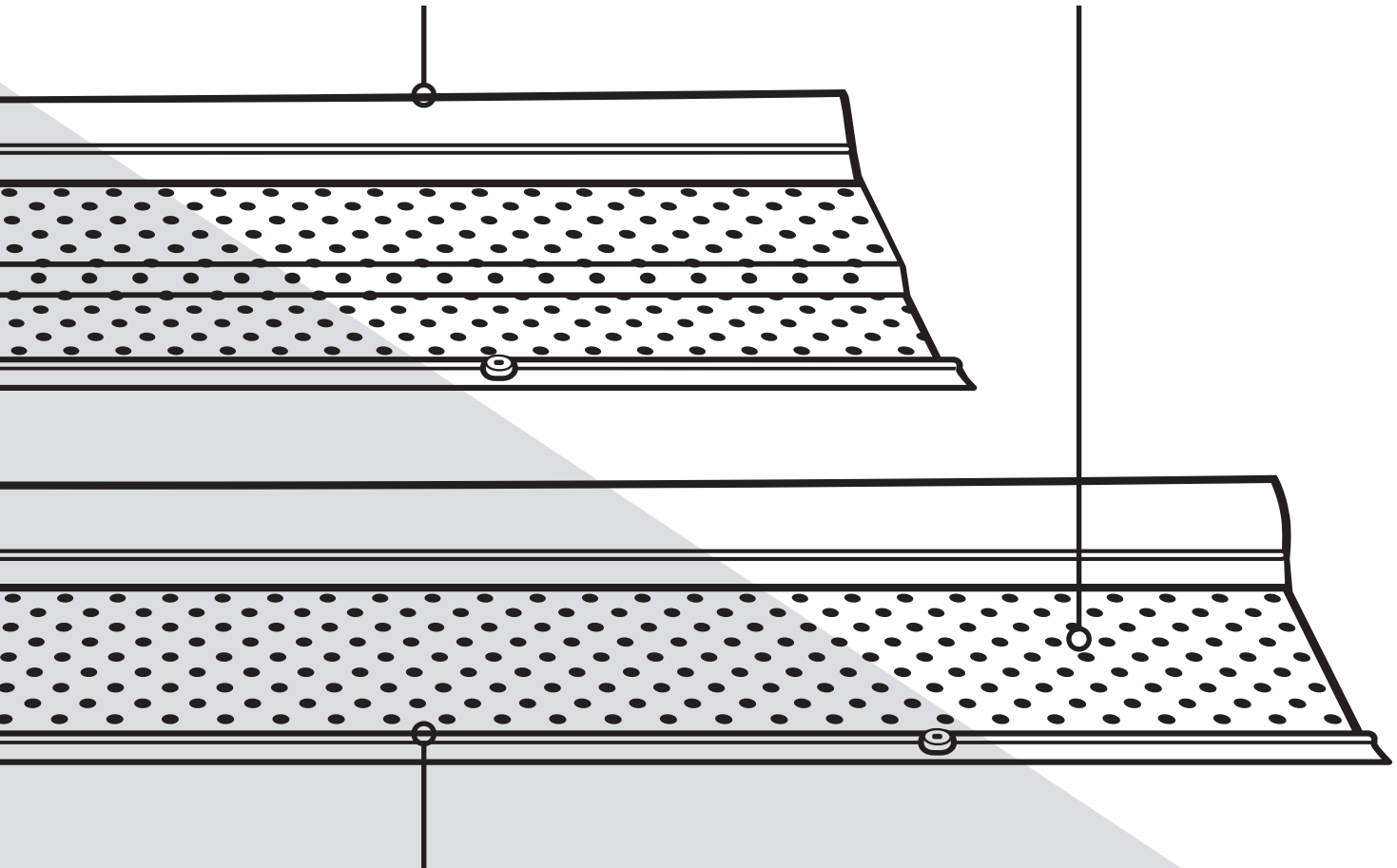

### roll@back<sup>™</sup> TECHNOLOGY

This technology sends excess rainwater back into the gutter for truly high-volume drainage capabilities.

**TO ORDER**



**M-5300 B95** **CARBON BLACK**

**PRODUCT** Aluminum  
Carbon Black backer  
Length: 7.44'  
Thickness: 0.017"

**PACKAGING** 43 pcs per ctn  
320' per ctn  
Ctn: 90" x 12" x 5" 42 lb  
24 ctns per skid (7,680')  
Skid: 92" x 45" 1,008 lb

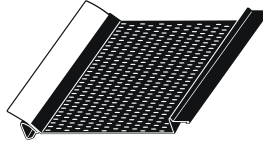

**M-5300** **MILL**

**PRODUCT** Aluminum  
Gold backer  
Length: 7.44'  
Thickness: 0.017"

**PACKAGING** 43 pcs per ctn  
320' per ctn  
Ctn: 90" x 12" x 5" 42 lb  
24 ctns per skid (7,680')  
Skid: 92" x 45" 1,008 lb

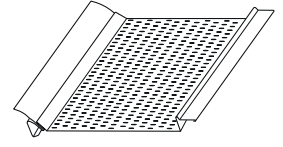

**M-53ZIP B95** **CARBON BLACK**

**PRODUCT** Aluminum  
Carbon Black backer  
Length: 7.44'  
Thickness: 0.017"

**PACKAGING** 43 pcs per ctn  
320' per ctn  
Ctn: 90" x 12" x 6" 52 lb  
21 ctns per skid (6,720')  
Skid: 92" x 45" 1,092 lb

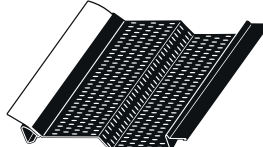

**M-53ZIP** **MILL**

**PRODUCT** Aluminum  
Gold backer  
Length: 7.44'  
Thickness: 0.017"

**PACKAGING** 43 pcs per ctn  
320' per ctn  
Ctn: 90" x 12" x 6" 52 lb  
21 ctns per skid (6,720')  
Skid: 92" x 45" 1,092 lb

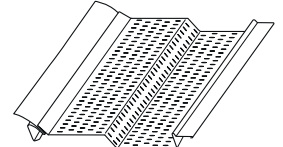

**MC-5300** **COPPER**

**PRODUCT** Copper  
100 screws included  
Length: 7.5'  
Thickness: 0.016"

**PACKAGING** 16 pcs per ctn  
120' per ctn  
Ctn: 90" x 7" x 3" 48 lb  
35 ctns per skid (4,200')  
Skid: 92" x 45" 1,680 lb

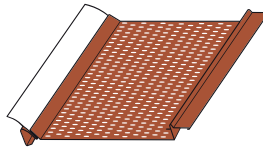

**M-6300 B95** **CARBON BLACK**

**PRODUCT** Aluminum  
Carbon Black backer  
Length: 7.44'  
Thickness: 0.017"

**PACKAGING** 43 pcs per ctn  
320' per ctn  
Ctn: 90" x 13" x 6" 52 lb  
21 ctns per skid (6,720')  
Skid: 92" x 45" 1,092 lb

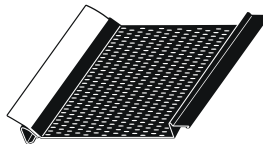

**M-6300** **MILL**

**PRODUCT** Aluminum  
Gold backer  
Length: 7.44'  
Thickness: 0.017"

**PACKAGING** 43 pcs per ctn  
320' per ctn  
Ctn: 90" x 13" x 6" 52 lb  
21 ctns per skid (6,720')  
Skid: 92" x 45" 1,092 lb

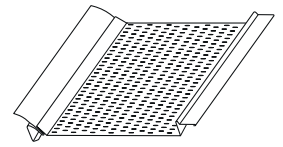

**M-63ZIP B95** **CARBON BLACK**

**PRODUCT** Aluminum  
Carbon Black backer  
Length: 7.44'  
Thickness: 0.017"

**PACKAGING** 43 pcs per ctn  
320' per ctn  
Ctn: 90" x 13" x 6" 54 lb  
21 ctns per skid (6,720')  
Skid: 92" x 45" 1,134 lb

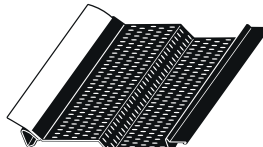

**M-63ZIP** **MILL**

**PRODUCT** Aluminum  
Gold backer  
Length: 7.44'  
Thickness: 0.017"

**PACKAGING** 43 pcs per ctn  
320' per ctn  
Ctn: 90" x 13" x 6" 54 lb  
21 ctns per skid (6,720')  
Skid: 92" x 45" 1,134 lb

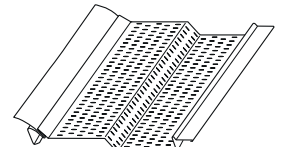

**MC-6300** **COPPER**

**PRODUCT** Copper  
100 screws included  
Length: 7.5'  
Thickness: 0.016"

**PACKAGING** 16 pcs per ctn  
120' per ctn  
Ctn: 90" x 7" x 3" 56 lb  
35 ctns per skid (4,200')  
Skid: 92" x 45" 1,960 lb

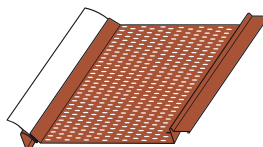

# RAIN GUTTER PROTECTION FOR HALF-ROUND GUTTERS

## TO ORDER



### HR-540 **MILL** **INSIDE BEAD**

**PRODUCT** Aluminum  
Gold backer  
Length: 7.5'  
Thickness: 0.0215"

**PACKAGING** 16 pcs per ctn  
120' per ctn  
Ctn: 90.25" x 7.75" x 2.25" 22 lb  
40 ctns per skid (4,800')  
Skid: 92" x 45" 880 lb

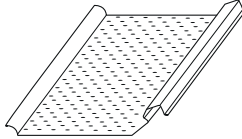

### HRC-5400 **COPPER** **INSIDE BEAD**

**PRODUCT** Copper  
100 screws included  
Length: 7.5'  
Thickness: 0.016"

**PACKAGING** 16 pcs per ctn  
120' per ctn  
Ctn: 90.25" x 7.75" x 2.25" 49 lb  
24 ctns per skid (2,880')  
Skid: 92" x 45" 1,176 lb

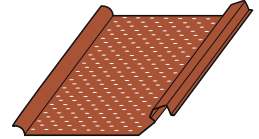

### HR-6400 **MILL** **INSIDE BEAD**

**PRODUCT** Aluminum  
Gold backer  
Length: 7.5'  
Thickness: 0.0215"

**PACKAGING** 16 pcs per ctn  
120' per ctn  
Ctn: 90.25" x 7.75" x 2.25" 25 lb  
40 ctns per skid (4,800')  
Skid: 92" x 45" 1,000 lb

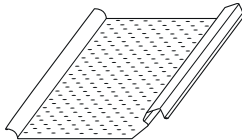

### HRC-6400 **COPPER** **INSIDE BEAD**

**PRODUCT** Copper  
100 screws included  
Length: 7.5'  
Thickness: 0.016"

**PACKAGING** 16 pcs per ctn  
120' per ctn  
Ctn: 90.25" x 7.75" x 2.25" 57 lb  
24 ctns per skid (2,880')  
Skid: 92" x 45" 1,368 lb

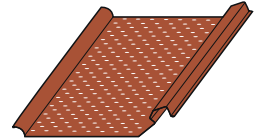

### HR333D-20 **CLEAR** **OUTSIDE BEAD**

**PRODUCT** Aluminum  
Clear backer  
44 Stainless steel clips included  
40 Stainless steel supports included  
Length: 6.6' (2m)  
Thickness: 0.0215"

**PACKAGING** 10 pcs per ctn  
65.62' (20m) per ctn  
Ctn: 90.25" x 7.75" x 2.25" 16 lb  
48 ctns per skid (4,800')  
Skid: 92" x 45" 880 lb

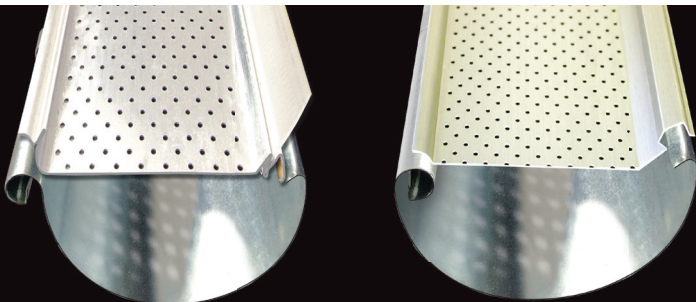
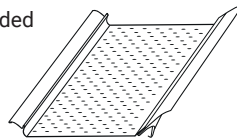

## COMPATIBILITY

Multiple profiles of half-round gutters are available on the market. Make sure your style of gutter matches our product specifications.

# COMPARISON OF GUTTER SYSTEMS

## HANGING SYSTEMS



Sturdiness



Drainage



Leaves Protection



Needles Protection



Easy to Maintain



Sturdiness Warranty



Clog-Free Warranty

**double pro**  
Continuous Hanger™  
with Built-In  
Gutter Guard



Lifetime warranty

Lifetime warranty

**t rex**  
Continuous Hanger™



Lifetime warranty

25-year warranty

Spaced Hangers



No protection

No protection



No warranty

No warranty

## GUTTER GUARDS

Sturdiness

Drainage

Leaves Protection

Needles Protection

Easy to Maintain

Sturdiness Warranty

Clog-Free Warranty

**double pro**  
Continuous Hanger™  
with Built-In  
Gutter Guard



Lifetime warranty

Lifetime warranty

**gutter clean pro**  
Retrofit Dual-Layer  
Microfiltration Gutter  
Protection



No warranty

Lifetime warranty

**gutter clean**  
Retrofit Rain Gutter  
Protection



No warranty

25-year warranty

Metal Screens



No warranty

From 0 years to 20 or 25 years

Micromesh



No warranty

From 25 years to lifetime

Reverse Curve

No sturdiness



No warranty

Lifetime warranty

Inserts (foam or brush)

No sturdiness



No warranty

From 1 year to 5 years



# LEADING THE WAY TOWARD INNOVATION

Our patents and trademarks reflect our commitment to excellence, innovation, and the pursuit of new industry standards through dedicated research and development.

Alu-Rex continuous hanger™ products pass ASTM: E2768 and ASTM: E84-19B standards' requirements for Surface Burning Characteristics of building materials. In the event of a fire, Alu-Rex products can help limit the spread of flames, potentially protecting homes from further damage.



Passed  
**ASTM**  
E2768



Passed  
**ASTM**  
E84-19B



alu-r**ex**

ALU-REX.COM • 1.855.525.8739